

TORKELSON

STEEL hylla 110/ STEEL shelf 110

Kan utrustas med olika hyllplan, lådor och hjul / Can be equipped with different shelves, drawers and wheels.

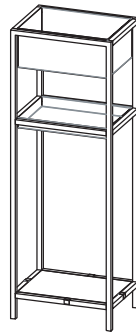

Delar / Parts



① x2

② x6

Ⓐ x12 M6x12

Ⓑ x12

Ⓒ x12

Ⓓ x1

1.

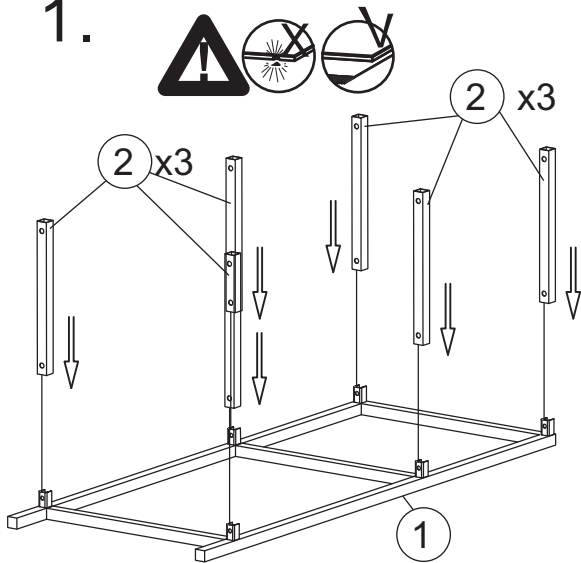

2.

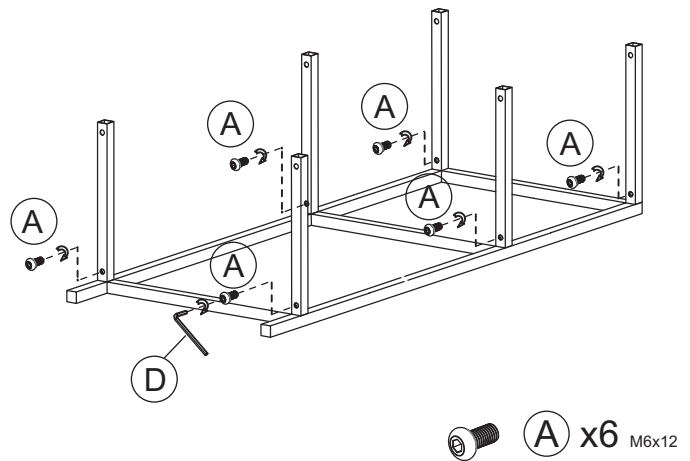

3.

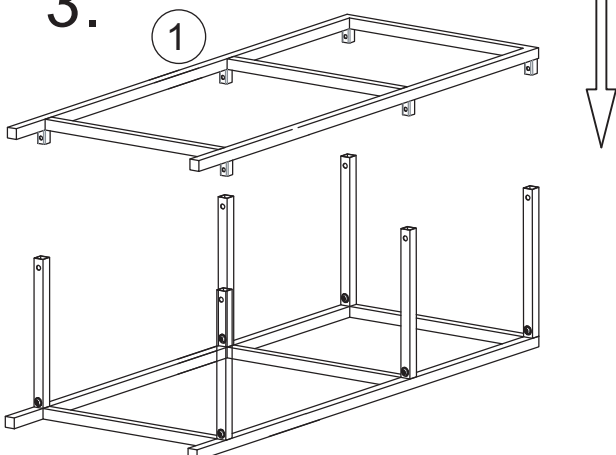

4.

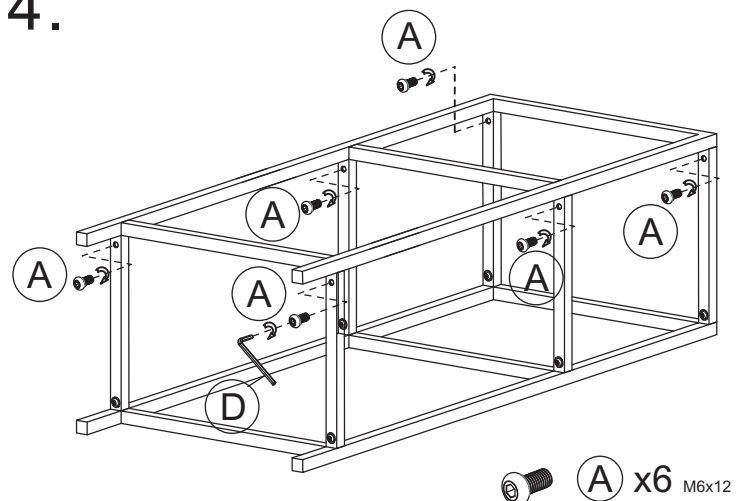

TORKELSON

STEEL hylla 110/ STEEL shelf 110

